

LM25101A/B/C 3A, 2A and 1A High Voltage High-Side and Low-Side Gate Drivers

Check for Samples: [LM25101](#), [LM25101A](#), [LM25101B](#), [LM25101C](#)

FEATURES

- Drives both a high-side and low-side N-Channel MOSFETs
- Independent high and low driver logic inputs
- Bootstrap supply voltage up to 100V DC
- Fast propagation times (25 ns typical)
- Drives 1000 pF load with 8 ns rise and fall times
- Excellent propagation delay matching (3 ns typical)
- Supply rail under-voltage lockout

- Low power consumption
- Pin compatible with HIP2100/HIP2101

TYPICAL APPLICATIONS

- Current Fed push-pull converters
- Half and Full Bridge power converters
- Synchronous buck converters
- Two switch forward power converters
- Forward with Active Clamp converters

DESCRIPTION

The LM25101A/B/C High Voltage Gate Drivers are designed to drive both the high-side and the low-side N-Channel MOSFETs in a synchronous buck or a half-bridge configuration. The “A” versions provide a full 3A of gate drive while the “B” and “C” versions provide 2A and 1A respectively. The outputs are independently controlled with TTL input thresholds. An integrated high voltage diode is provided to charge the high-side gate drive bootstrap capacitor. A robust level shifter operates at high speed while consuming low power and providing clean level transitions from the control logic to the high-side gate driver. Under-voltage lockout is provided on both the low-side and the high-side power rails. These devices are available in the standard SOIC-8 pin and HSOP-8 pin packages.

Package

- SOIC-8
- HSOP-8

Simplified Block Diagram

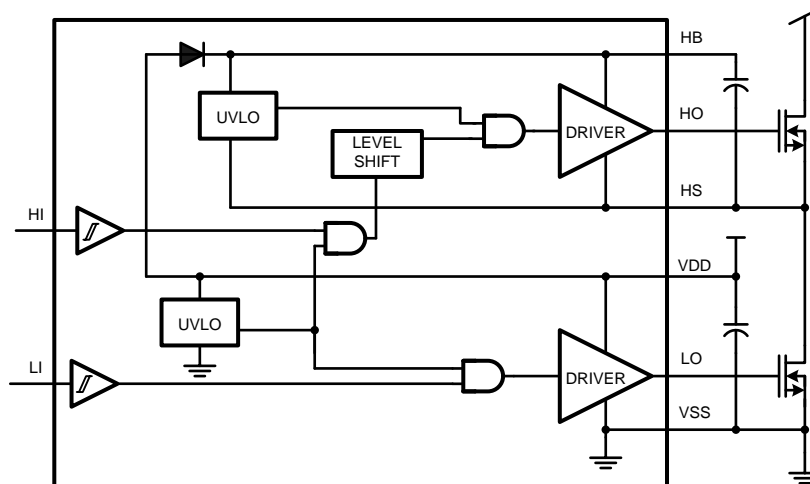

Please be aware that an important notice concerning availability, standard warranty, and use in critical applications of Texas Instruments semiconductor products and disclaimers thereto appears at the end of this data sheet.

All trademarks are the property of their respective owners.

Table 1. Input/Output Options

Part Number	Input Thresholds	Peak Output Current
LM25101A	TTL	3A
LM25101B	TTL	2A
LM25101C	TTL	1A

Connection Diagrams

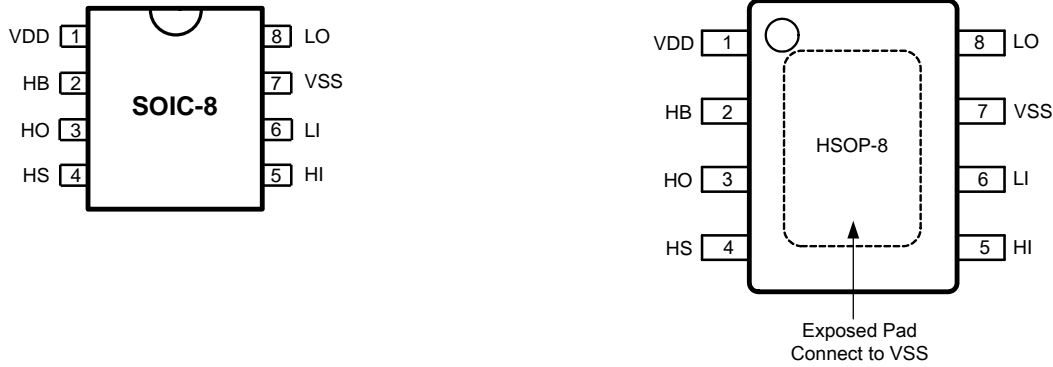

Pin Descriptions

Pin #		Name	Description	Application Information
SOIC-8	HSOP-8			
1	1	VDD	Positive gate drive supply	Locally decouple to VSS using low ESR/ESL capacitor located as close to the IC as possible.
2	2	HB	High-side gate driver bootstrap rail	Connect the positive terminal of the bootstrap capacitor to HB and the negative terminal to HS. The bootstrap capacitor should be placed as close to the IC as possible.
3	3	HO	High-side gate driver output	Connect to the gate of high-side MOSFET with a short, low inductance path.
4	4	HS	High-side MOSFET source connection	Connect to the bootstrap capacitor negative terminal and the source of the high-side MOSFET.
5	5	HI	High-side driver control input	The LM25101A/B/C inputs have TTL type thresholds. Unused inputs should be tied to ground and not left open.
6	6	LI	Low-side driver control input	The LM25101A/B/C inputs have TTL type thresholds. Unused inputs should be tied to ground and not left open.
7	7	VSS	Ground return	All signals are referenced to this ground.
8	8	LO	Low-side gate driver output	Connect to the gate of the low-side MOSFET with a short, low inductance path.
	EP	EP	Exposed pad	Solder to the ground plane under the IC to aid in heat dissipation.



These devices have limited built-in ESD protection. The leads should be shorted together or the device placed in conductive foam during storage or handling to prevent electrostatic damage to the MOS gates.

Absolute Maximum Ratings⁽¹⁾

VDD to VSS	-0.3V to +18V
HB to HS	-0.3V to +18V
LI or HI Input	-0.3V to V _{DD} +0.3V
LO Output	-0.3V to V _{DD} +0.3V
HO Output	V _{HS} -0.3V to V _{HB} +0.3V
HS to VSS ⁽²⁾	-5V to +100V
HB to VSS	100V
Junction Temperature	+150°C
Storage Temperature Range	-55°C to +150°C
ESD Rating, HBM ⁽³⁾	2 kV

- (1) Absolute Maximum Ratings indicate limits beyond which damage to the component may occur. Operating Ratings are conditions under which operation of the device is guaranteed. Operating Ratings do not imply guaranteed performance limits. For guaranteed performance limits and associated test conditions, see the Electrical Characteristics tables.
- (2) In the application the HS node is clamped by the body diode of the external lower N-MOSFET, therefore the HS node will generally not exceed -1V. However, in some applications, board resistance and inductance may result in the HS node exceeding this stated voltage transiently. If negative transients occur, the HS voltage must never be more negative than V_{DD}-15V. For example if V_{DD} = 10V, the negative transients at HS must not exceed -5V.
- (3) The Human Body Model (HBM) is a 100 pF capacitor discharged through a 1.5kΩ resistor into each pin. 2 kV for all pins except Pin 2, Pin 3 and Pin 4 which are rated at 1000V for HBM. Machine Model (MM) rating is 100V.

Recommended Operating Conditions

VDD	+9V to +14V
HS	-1V to 100V - V _{DD}
HB	V _{HS} +8V to V _{HS} +14V
HS Slew Rate	< 50 V/ns
Junction Temperature	-40°C to +125°C

Electrical Characteristics

Limits in standard type are for T_J = 25°C only; limits in boldface type apply over the junction temperature (T_J) range of -40°C to +125°C. Minimum and Maximum limits are guaranteed through test, design, or statistical correlation. Typical values represent the most likely parametric norm at T_J = 25°C, and are provided for reference purposes only. Unless otherwise specified, V_{DD} = V_{HB} = 12V, V_{SS} = V_{HS} = 0V, No Load on LO or HO⁽¹⁾.

Symbol	Parameter	Conditions	Min	Typ	Max	Unit
SUPPLY CURRENTS						
I _{DD}	VDD Quiescent Current, LM25101A/B/C	LI = HI = 0V		0.25	0.4	mA
I _{DDO}	VDD Operating Current	f = 500 kHz		2.0	3	mA
I _{HB}	Total HB Quiescent Current	LI = HI = 0V		0.06	0.2	mA
I _{HBO}	Total HB Operating Current	f = 500 kHz		1.6	3	mA
I _{HBS}	HB to VSS Current, Quiescent	HS = HB = 100V		0.1	10	μA
I _{HBSO}	HB to VSS Current, Operating	f = 500 kHz		0.4		mA
INPUT PINS						
V _{IL}	Input Voltage Threshold LM25101A/B/C	Rising Edge	1.3	1.8	2.3	V
V _{IHYS}	Input Voltage Hysteresis LM25101A/B/C			50		mV
R _I	Input Pulldown Resistance		100	200	400	kΩ
UNDER VOLTAGE PROTECTION						
V _{DDR}	VDD Rising Threshold		6.0	6.9	7.4	V
V _{DDH}	VDD Threshold Hysteresis			0.5		V
V _{HBR}	HB Rising Threshold		5.7	6.6	7.1	V
V _{HBH}	HB Threshold Hysteresis			0.4		V
BOOT STRAP DIODE						

- (1) Min and Max limits are 100% production tested at 25°C. Limits over the operating temperature range are guaranteed through correlation using Statistical Quality Control (SQC) methods. Limits are used to calculate National's Average Outgoing Quality Level (AOQL).

Electrical Characteristics (continued)

Limits in standard type are for $T_J = 25^\circ\text{C}$ only; limits in boldface type apply over the junction temperature (T_J) range of -40°C to $+125^\circ\text{C}$. Minimum and Maximum limits are guaranteed through test, design, or statistical correlation. Typical values represent the most likely parametric norm at $T_J = 25^\circ\text{C}$, and are provided for reference purposes only. Unless otherwise specified, $V_{DD} = V_{HB} = 12\text{V}$, $V_{SS} = V_{HS} = 0\text{V}$, No Load on LO or HO ⁽¹⁾.

Symbol	Parameter	Conditions	Min	Typ	Max	Unit
V_{DL}	Low-Current Forward Voltage	$I_{VDD-HB} = 100 \mu\text{A}$		0.52	0.85	V
V_{DH}	High-Current Forward Voltage	$I_{VDD-HB} = 100 \text{mA}$		0.8	1	V
RD	Dynamic Resistance LM25101A/B/C	$I_{VDD-HB} = 100 \text{mA}$		1.0	1.65	Ω
LO & HO GATE DRIVER						
V_{OL}	Low-Level Output Voltage LM25101A	$I_{HO} = I_{LO} = 100 \text{mA}$		0.12	0.25	V
	Low-Level Output Voltage LM25101B			0.16	0.4	
	Low-Level Output Voltage LM25101C			0.28	0.65	
V_{OH}	High-Level Output Voltage LM25101A	$I_{HO} = I_{LO} = 100 \text{mA}$ $V_{OH} = V_{DD} - LO$ or $V_{OH} = HB - HO$		0.24	0.45	V
	High-Level Output Voltage LM25101B			0.28	0.60	
	High-Level Output Voltage LM25101C			0.60	1.10	
I_{OHL}	Peak Pullup Current LM25101A	HO, LO = 0V		3		A
	Peak Pullup Current LM25101B			2		
	Peak Pullup Current LM25101C			1		
I_{OLL}	Peak Pulldown Current LM25101A	HO, LO = 12V		3		A
	Peak Pulldown Current LM25101B			2		
	Peak Pulldown Current LM25101C			1		
THERMAL RESISTANCE						
θ_{JA}	Junction to Ambient ⁽²⁾	SOIC-8		170		$^\circ\text{C/W}$
		HSOP-8		40		

(2) The θ_{JA} is not a given constant for the package and depends on the printed circuit board design and the operating environment.

Switching Characteristics

Limits in standard type are for $T_J = 25^\circ\text{C}$ only; limits in boldface type apply over the junction temperature (T_J) range of -40°C to $+125^\circ\text{C}$. Minimum and Maximum limits are guaranteed through test, design, or statistical correlation. Typical values represent the most likely parametric norm at $T_J = 25^\circ\text{C}$, and are provided for reference purposes only. Unless otherwise specified, $V_{DD} = V_{HB} = 12\text{V}$, $V_{SS} = V_{HS} = 0\text{V}$, No Load on LO or HO ⁽¹⁾.

Symbol	Parameter	Conditions	Min	Typ	Max	Unit
t_{LPHL}	LO Turn-Off Propagation Delay	LI Falling to LO Falling		22	56	ns
t_{LPLH}	LO Turn-On Propagation Delay	LI Rising to LO Rising		26	56	ns
t_{HPHL}	HO Turn-Off Propagation Delay	HI Falling to HO Falling		22	56	ns
t_{HPLH}	HO Turn-On Propagation Delay	HI Rising to HO Rising		26	56	ns
t_{MON}	Delay Matching: LO on & HO Off			4	10	ns
t_{MOFF}	Delay Matching: LO on & HO Off			4	10	ns
t_{RC}, t_{FC}	Either Output Rise/Fall Time	$C_L = 1000\text{ pF}$		8		ns
t_R	Output Rise Time (3V to 9V) LM25101A	$C_L = 0.1\text{ }\mu\text{F}$		430		ns
	Output Rise Time (3V to 9V) LM25101B			570		
	Output Rise Time (3V to 9V) LM25101C			990		
t_F	Output Fall Time (3V to 9V) LM25101A	$C_L = 0.1\text{ }\mu\text{F}$		260		ns
	Output Fall Time (3V to 9V) LM25101B			430		
	Output Fall Time (3V to 9V) LM25101C			715		
t_{PW}	Minimum input pulse duration that changes the output			50		ns
t_{BS}	Bootstrap diode reverse recovery time	$I_F = 100\text{ mA}$, $I_R = 100\text{ mA}$		37		ns

- (1) Min and Max limits are 100% production tested at 25°C . Limits over the operating temperature range are guaranteed through correlation using Statistical Quality Control (SQC) methods. Limits are used to calculate National's Average Outgoing Quality Level (AOQL).

Typical Performance Characteristics

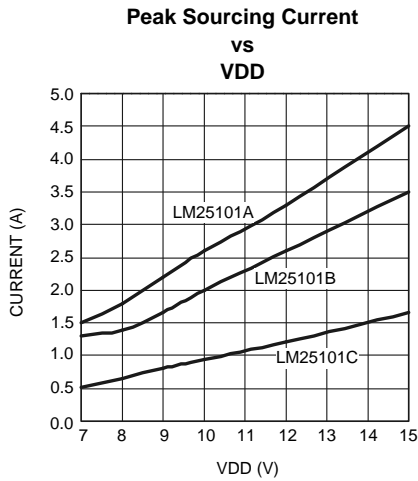

Figure 1.

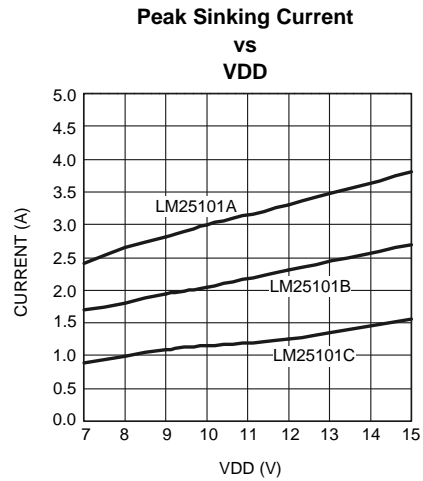

Figure 2.

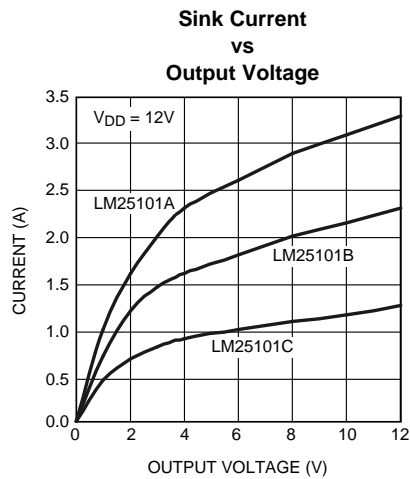

Figure 3.

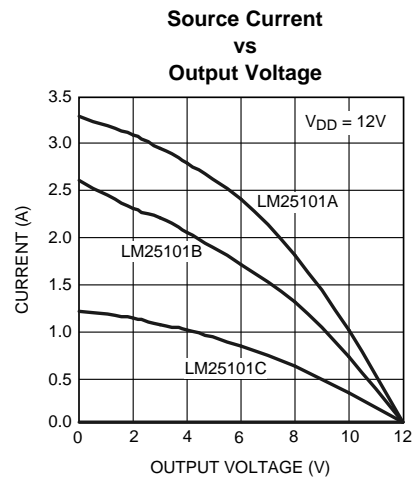

Figure 4.

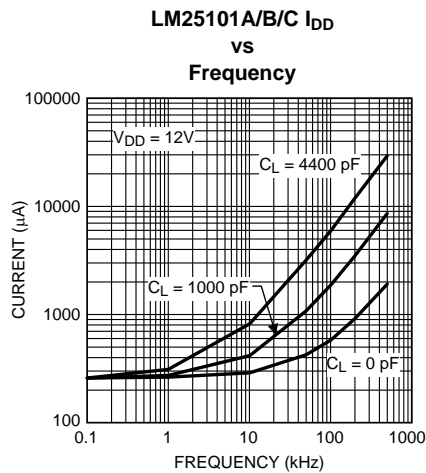

Figure 5.

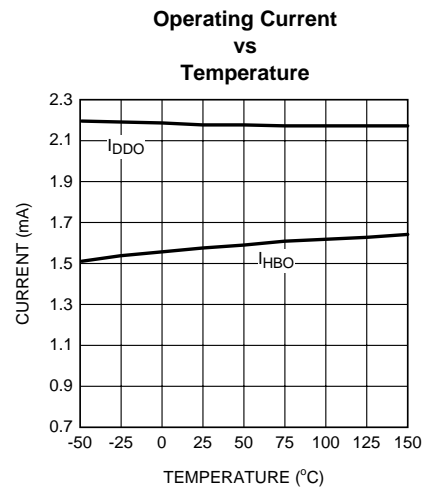

Figure 6.

Typical Performance Characteristics (continued)

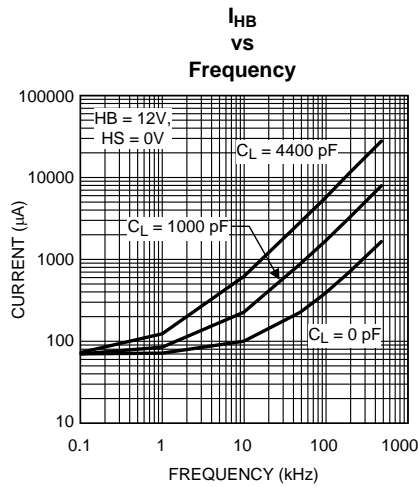

Figure 7.

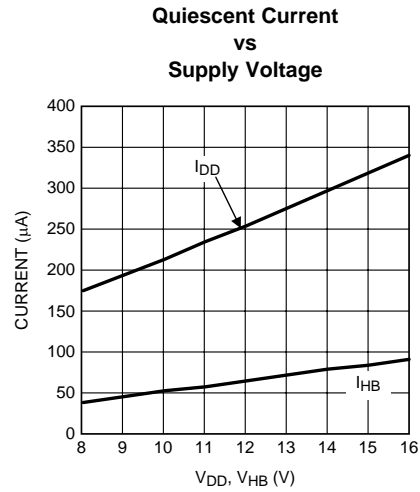

Figure 8.

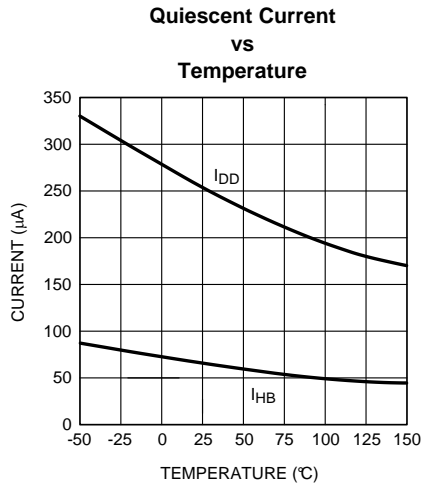

Figure 9.

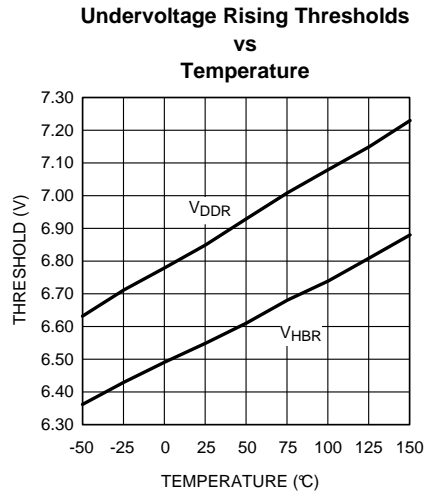

Figure 10.

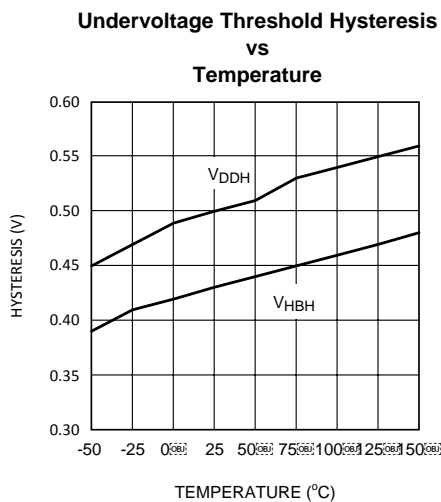

Figure 11.

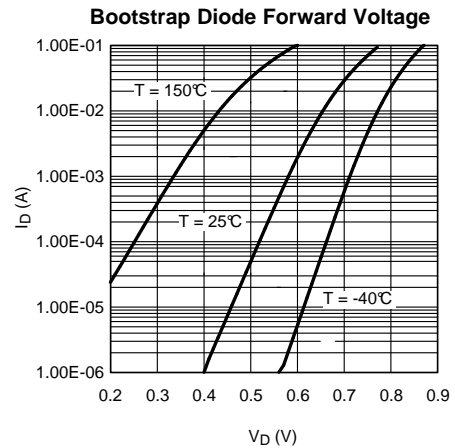

Figure 12.

Typical Performance Characteristics (continued)

LM25101A/B/C Input Threshold vs Temperature

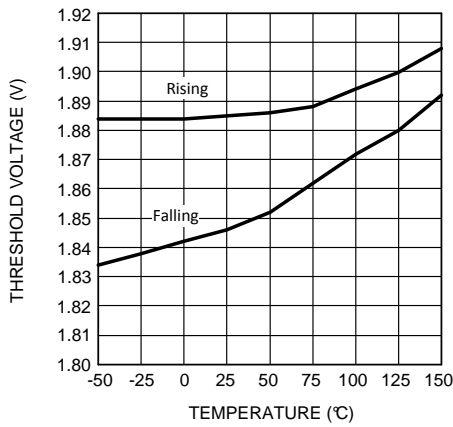

Figure 13.

LM25101A/B/C Input Threshold vs VDD

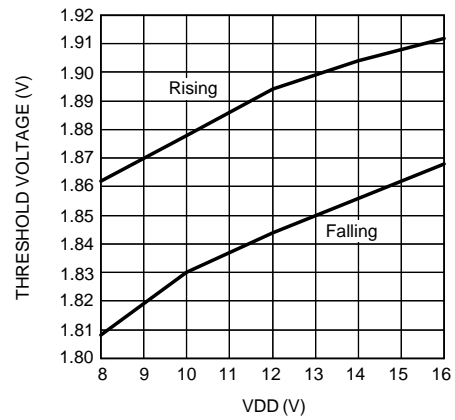

Figure 14.

LM25101A/B/C Propagation Delay vs Temperature

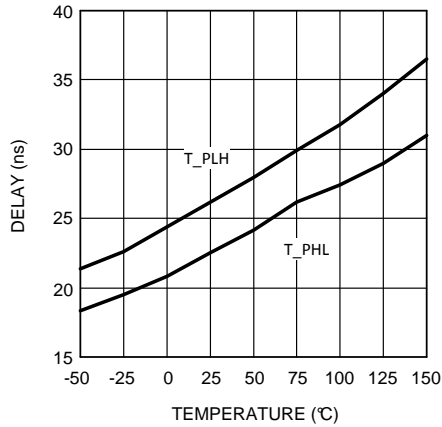

Figure 15.

LO & HO Gate Drive - High Level Output Voltage vs Temperature

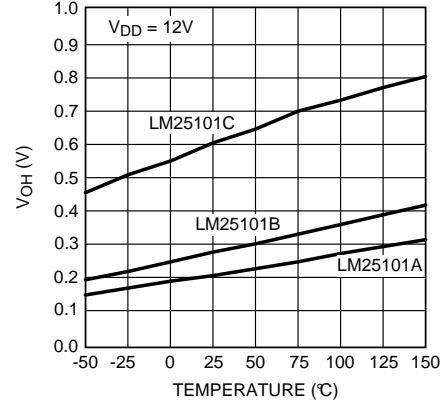

Figure 16.

LO & HO Gate Drive - Low Level Output Voltage vs Temperature

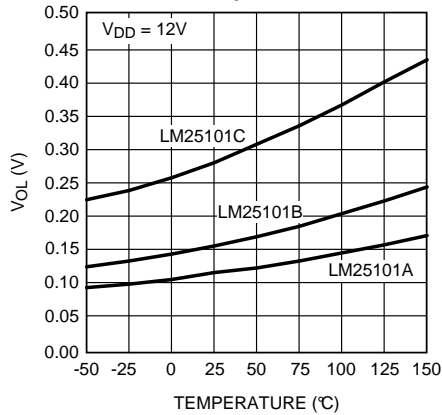

Figure 17.

LO & HO Gate Drive - Output High Voltage vs VDD

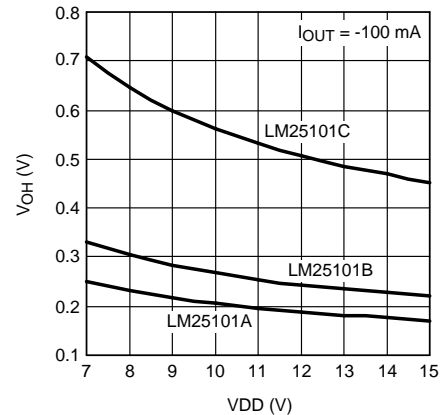

Figure 18.

Typical Performance Characteristics (continued)

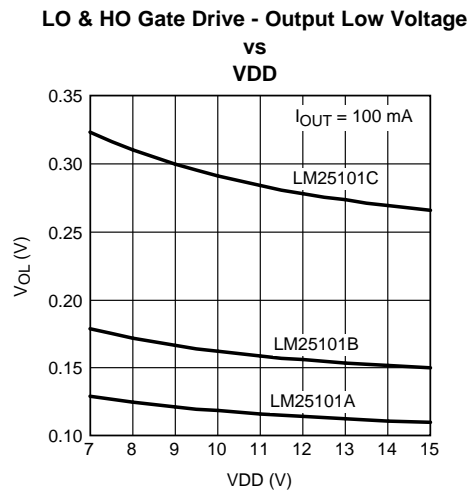
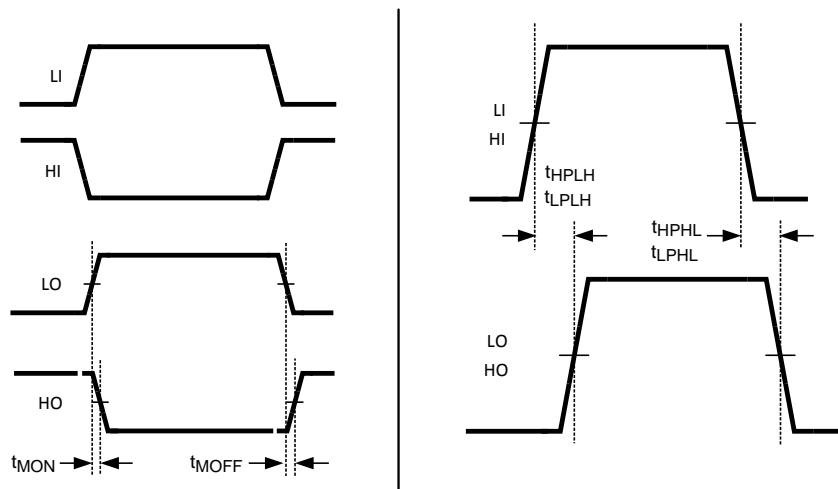

Figure 19.

TIMING DIAGRAM



Layout Considerations

The optimum performance of high and low-side gate drivers cannot be achieved without taking due considerations during circuit board layout. Following points are emphasized.

1. Low ESR / ESL capacitors must be connected close to the IC, between VDD and VSS pins and between the HB and HS pins to support the high peak currents being drawn from VDD during turn-on of the external MOSFET.
2. To prevent large voltage transients at the drain of the top MOSFET, a low ESR electrolytic capacitor must be connected between MOSFET drain and ground (VSS).
3. In order to avoid large negative transients on the switch node (HS pin), the parasitic inductances in the source of top MOSFET and in the drain of the bottom MOSFET (synchronous rectifier) must be minimized.
4. Grounding Considerations:
 - (a) The first priority in designing grounding connections is to confine the high peak currents that charge and discharge the MOSFET gate into a minimal physical area. This will decrease the loop inductance and minimize noise issues on the gate terminal of the MOSFET. The MOSFETs should be placed as close as possible to the gate driver.
 - (b) The second high current path includes the bootstrap capacitor, the bootstrap diode, the local ground referenced bypass capacitor and low-side MOSFET body diode. The bootstrap capacitor is recharged on a cycle-by-cycle basis through the bootstrap diode from the ground referenced VDD bypass capacitor. The recharging occurs in a short time interval and involves high peak current. Minimizing this loop length and area on the circuit board is important to ensure reliable operation.

A recommended layout pattern for the driver is shown in [Figure 20](#). If possible a single layer placement is preferred.

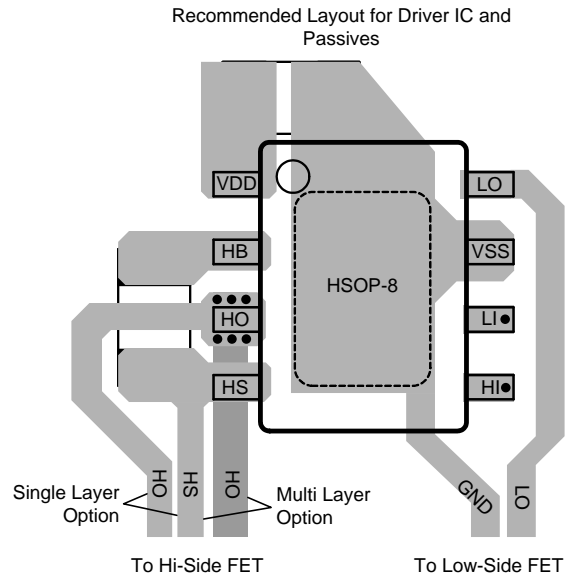

Figure 20. Recommended Layout Pattern

Power Dissipation Considerations

The total IC power dissipation is the sum of the gate driver losses and the bootstrap diode losses. The gate driver losses are related to the switching frequency (f), output load capacitance on LO and HO (C_L), and supply voltage (V_{DD}) and can be roughly calculated as:

$$P_{DGATES} = 2 \cdot f \cdot C_L \cdot V_{DD}^2 \quad (1)$$

There are some additional losses in the gate drivers due to the internal CMOS stages used to buffer the LO and HO outputs. Figure 21 shows the measured gate driver power dissipation versus frequency and load capacitance. At higher frequencies and load capacitance values, the power dissipation is dominated by the power losses driving the output loads and agrees well with Equation 1. This plot can be used to approximate the power losses due to the gate drivers.

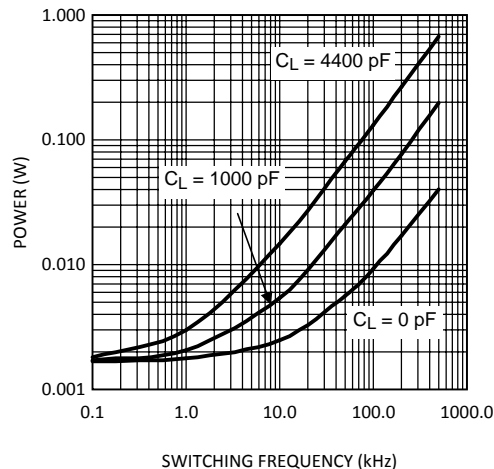

Figure 21. Gate Driver Power Dissipation (LO + HO)
 $V_{DD} = 12V$, Neglecting Diode Losses

The bootstrap diode power loss is the sum of the forward bias power loss that occurs while charging the bootstrap capacitor and the reverse bias power loss that occurs during reverse recovery. Since each of these events happens once per cycle, the diode power loss is proportional to frequency. Larger capacitive loads require more energy to recharge the bootstrap capacitor resulting in more losses. Higher input voltages (V_{IN}) to the half bridge result in higher reverse recovery losses. Figure 22 was generated based on calculations and lab measurements of the diode recovery time and current under several operating conditions. This can be useful for approximating the diode power dissipation.

The total IC power dissipation can be estimated from the previous plots by summing the gate drive losses with the bootstrap diode losses for the intended application.

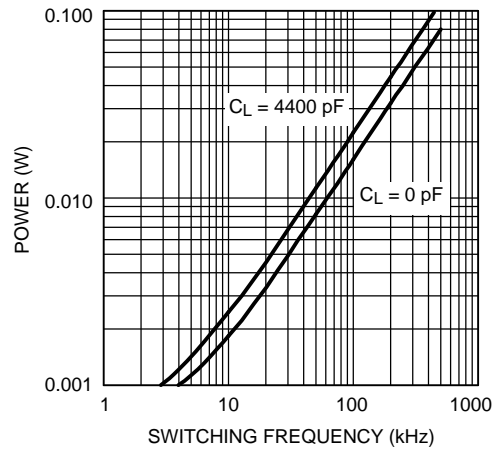

Figure 22. Diode Power Dissipation $V_{IN} = 50V$

PACKAGING INFORMATION

Orderable Device	Status (1)	Package Type	Package Drawing	Pins	Package Qty	Eco Plan (2)	Lead/Ball Finish	MSL Peak Temp (3)	Op Temp (°C)	Top-Side Markings (4)	Samples
LM25101AM/NOPB	ACTIVE	SOIC	D	8	95	Green (RoHS & no Sb/Br)	CU SN	Level-1-260C-UNLIM	-40 to 125	L25101 AM	Samples
LM25101AMR/NOPB	ACTIVE	SO PowerPAD	DDA	8	95	Green (RoHS & no Sb/Br)	CU SN	Level-3-260C-168 HR	-40 to 125	L25101 AMR	Samples
LM25101AMRX/NOPB	ACTIVE	SO PowerPAD	DDA	8	2500	Green (RoHS & no Sb/Br)	CU SN	Level-3-260C-168 HR	-40 to 125	L25101 AMR	Samples
LM25101AMX/NOPB	ACTIVE	SOIC	D	8	2500	Green (RoHS & no Sb/Br)	CU SN	Level-1-260C-UNLIM	-40 to 125	L25101 AM	Samples
LM25101BMA/NOPB	ACTIVE	SOIC	D	8	95	Green (RoHS & no Sb/Br)	CU SN	Level-1-260C-UNLIM	-40 to 125	L25101 BMA	Samples
LM25101BMAX/NOPB	ACTIVE	SOIC	D	8	2500	Green (RoHS & no Sb/Br)	CU SN	Level-1-260C-UNLIM	-40 to 125	L25101 BMA	Samples
LM25101CMA/NOPB	ACTIVE	SOIC	D	8	95	Green (RoHS & no Sb/Br)	CU SN	Level-1-260C-UNLIM	-40 to 125	L25101 CMA	Samples
LM25101CMAX/NOPB	ACTIVE	SOIC	D	8	2500	Green (RoHS & no Sb/Br)	CU SN	Level-1-260C-UNLIM	-40 to 125	L25101 CMA	Samples

(1) The marketing status values are defined as follows:

ACTIVE: Product device recommended for new designs.

LIFEBUY: TI has announced that the device will be discontinued, and a lifetime-buy period is in effect.

NRND: Not recommended for new designs. Device is in production to support existing customers, but TI does not recommend using this part in a new design.

PREVIEW: Device has been announced but is not in production. Samples may or may not be available.

OBSOLETE: TI has discontinued the production of the device.

(2) Eco Plan - The planned eco-friendly classification: Pb-Free (RoHS), Pb-Free (RoHS Exempt), or Green (RoHS & no Sb/Br) - please check <http://www.ti.com/productcontent> for the latest availability information and additional product content details.

TBD: The Pb-Free/Green conversion plan has not been defined.

Pb-Free (RoHS): TI's terms "Lead-Free" or "Pb-Free" mean semiconductor products that are compatible with the current RoHS requirements for all 6 substances, including the requirement that lead not exceed 0.1% by weight in homogeneous materials. Where designed to be soldered at high temperatures, TI Pb-Free products are suitable for use in specified lead-free processes.

Pb-Free (RoHS Exempt): This component has a RoHS exemption for either 1) lead-based flip-chip solder bumps used between the die and package, or 2) lead-based die adhesive used between the die and leadframe. The component is otherwise considered Pb-Free (RoHS compatible) as defined above.

Green (RoHS & no Sb/Br): TI defines "Green" to mean Pb-Free (RoHS compatible), and free of Bromine (Br) and Antimony (Sb) based flame retardants (Br or Sb do not exceed 0.1% by weight in homogeneous material)

(3) MSL, Peak Temp. -- The Moisture Sensitivity Level rating according to the JEDEC industry standard classifications, and peak solder temperature.

⁽⁴⁾ Only one of markings shown within the brackets will appear on the physical device.

Important Information and Disclaimer: The information provided on this page represents TI's knowledge and belief as of the date that it is provided. TI bases its knowledge and belief on information provided by third parties, and makes no representation or warranty as to the accuracy of such information. Efforts are underway to better integrate information from third parties. TI has taken and continues to take reasonable steps to provide representative and accurate information but may not have conducted destructive testing or chemical analysis on incoming materials and chemicals. TI and TI suppliers consider certain information to be proprietary, and thus CAS numbers and other limited information may not be available for release.

In no event shall TI's liability arising out of such information exceed the total purchase price of the TI part(s) at issue in this document sold by TI to Customer on an annual basis.

DDA0008B

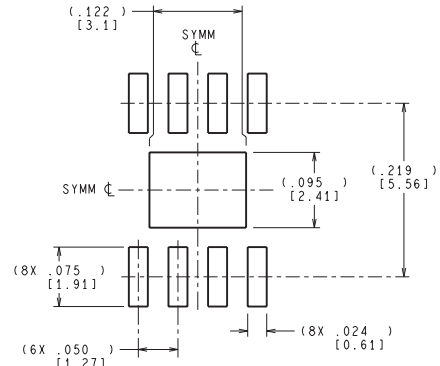
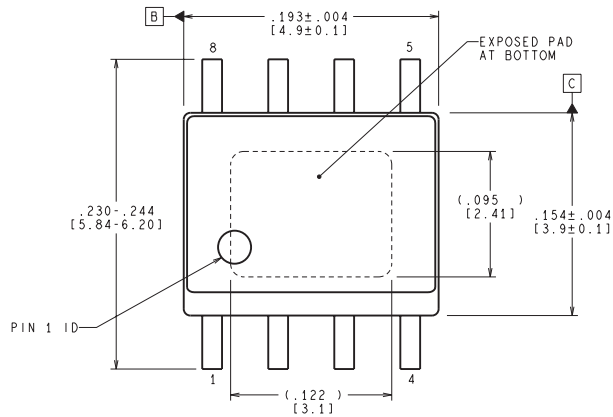

RECOMMENDED LAND PATTERN

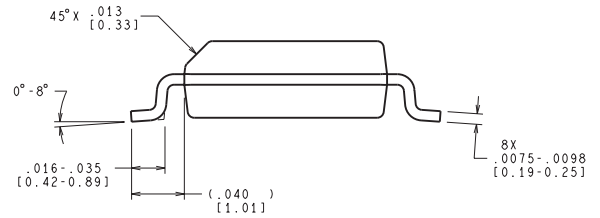
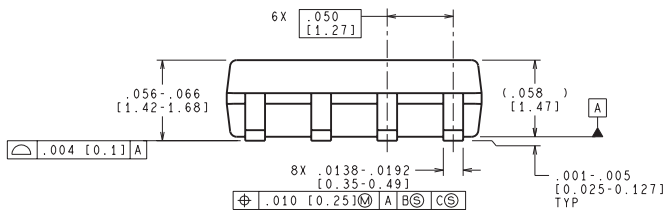

CONTROLLING DIMENSION IS INCH
 VALUES IN [] ARE MILLIMETERS
 DIMENSIONS IN () FOR REFERENCE ONLY

MRA08B (Rev B)

IMPORTANT NOTICE

Texas Instruments Incorporated and its subsidiaries (TI) reserve the right to make corrections, enhancements, improvements and other changes to its semiconductor products and services per JESD46, latest issue, and to discontinue any product or service per JESD48, latest issue. Buyers should obtain the latest relevant information before placing orders and should verify that such information is current and complete. All semiconductor products (also referred to herein as "components") are sold subject to TI's terms and conditions of sale supplied at the time of order acknowledgment.

TI warrants performance of its components to the specifications applicable at the time of sale, in accordance with the warranty in TI's terms and conditions of sale of semiconductor products. Testing and other quality control techniques are used to the extent TI deems necessary to support this warranty. Except where mandated by applicable law, testing of all parameters of each component is not necessarily performed.

TI assumes no liability for applications assistance or the design of Buyers' products. Buyers are responsible for their products and applications using TI components. To minimize the risks associated with Buyers' products and applications, Buyers should provide adequate design and operating safeguards.

TI does not warrant or represent that any license, either express or implied, is granted under any patent right, copyright, mask work right, or other intellectual property right relating to any combination, machine, or process in which TI components or services are used. Information published by TI regarding third-party products or services does not constitute a license to use such products or services or a warranty or endorsement thereof. Use of such information may require a license from a third party under the patents or other intellectual property of the third party, or a license from TI under the patents or other intellectual property of TI.

Reproduction of significant portions of TI information in TI data books or data sheets is permissible only if reproduction is without alteration and is accompanied by all associated warranties, conditions, limitations, and notices. TI is not responsible or liable for such altered documentation. Information of third parties may be subject to additional restrictions.

Resale of TI components or services with statements different from or beyond the parameters stated by TI for that component or service voids all express and any implied warranties for the associated TI component or service and is an unfair and deceptive business practice. TI is not responsible or liable for any such statements.

Buyer acknowledges and agrees that it is solely responsible for compliance with all legal, regulatory and safety-related requirements concerning its products, and any use of TI components in its applications, notwithstanding any applications-related information or support that may be provided by TI. Buyer represents and agrees that it has all the necessary expertise to create and implement safeguards which anticipate dangerous consequences of failures, monitor failures and their consequences, lessen the likelihood of failures that might cause harm and take appropriate remedial actions. Buyer will fully indemnify TI and its representatives against any damages arising out of the use of any TI components in safety-critical applications.

In some cases, TI components may be promoted specifically to facilitate safety-related applications. With such components, TI's goal is to help enable customers to design and create their own end-product solutions that meet applicable functional safety standards and requirements. Nonetheless, such components are subject to these terms.

No TI components are authorized for use in FDA Class III (or similar life-critical medical equipment) unless authorized officers of the parties have executed a special agreement specifically governing such use.

Only those TI components which TI has specifically designated as military grade or "enhanced plastic" are designed and intended for use in military/aerospace applications or environments. Buyer acknowledges and agrees that any military or aerospace use of TI components which have **not** been so designated is solely at the Buyer's risk, and that Buyer is solely responsible for compliance with all legal and regulatory requirements in connection with such use.

TI has specifically designated certain components as meeting ISO/TS16949 requirements, mainly for automotive use. In any case of use of non-designated products, TI will not be responsible for any failure to meet ISO/TS16949.

Products

Audio	www.ti.com/audio
Amplifiers	amplifier.ti.com
Data Converters	dataconverter.ti.com
DLP® Products	www.dlp.com
DSP	dsp.ti.com
Clocks and Timers	www.ti.com/clocks
Interface	interface.ti.com
Logic	logic.ti.com
Power Mgmt	power.ti.com
Microcontrollers	microcontroller.ti.com
RFID	www.ti-rfid.com
OMAP Applications Processors	www.ti.com/omap
Wireless Connectivity	www.ti.com/wirelessconnectivity

Applications

Automotive and Transportation	www.ti.com/automotive
Communications and Telecom	www.ti.com/communications
Computers and Peripherals	www.ti.com/computers
Consumer Electronics	www.ti.com/consumer-apps
Energy and Lighting	www.ti.com/energy
Industrial	www.ti.com/industrial
Medical	www.ti.com/medical
Security	www.ti.com/security
Space, Avionics and Defense	www.ti.com/space-avionics-defense
Video and Imaging	www.ti.com/video

TI E2E Community

e2e.ti.com